

# TBI MOTION BALL SPLINE

## 3-1 Nominal Model Code of Ball Spline SL Series

SLT Series Specifications

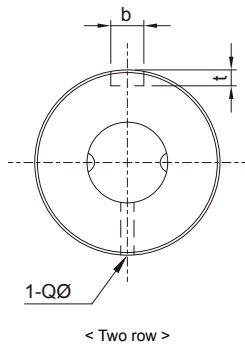

Shaft diameter  $d \leq 20$

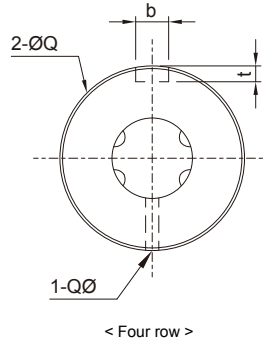

Shaft diameter  $d \geq 25$

Model No.	Diameter		Spline Nut Dimension					Keyway Dimensions	
	d	Row	D	L	S	L1	Oil Hole	b	t
	h7						Q		
SLT006	6	2	14	25	16.7	10.5	1	2.5	1.2
SLT008	8	2	16	27	15.7	10.5	1.5	2.5	1.2
SLT010	10	2	21	33	20	13	1.5	3	1.5
SLT013	13	2	24	36	23	15	1.5	3	1.5
SLT016	16	2	31	50	34	17.5	2	3.5	2
SLT020	20	2	35	56	39.7	29	2	4	2.5
SLT025	25	4	42	71	50.3	36	3	4	2.5
SLT030	30	4	47	80	60	42	3	4	2.5
SLT040	40	4	64	100	70	52	4	6	3.5
SLT050	50	4	80	125	91	58	4	8	4

B

Ball Spline

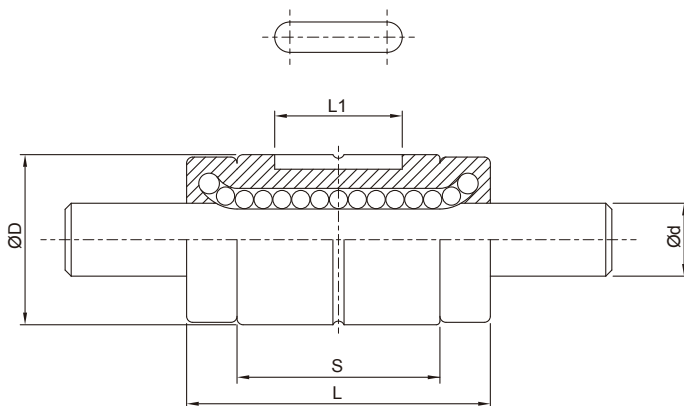

Model No.	Basic Load Rating		Basic Torsion		Static Permissible Moment		Weight	
	C	C <sub>0</sub>	C <sub>T</sub>	C <sub>0T</sub>	M <sub>A1</sub>	M <sub>A2</sub>	Spline Nut	Spline Shaft
	kgf	kgf	kgf · m	kgf · m	kgf · m	kgf · m	g	kg/m
SLT006	137	225	0.46	0.76	0.39	3.48	14	0.22
SLT008	137	225	0.60	0.99	0.39	3.82	16	0.39
SLT010	285	397	1.62	2.25	0.95	8.53	37	0.60
SLT013	396	540	2.89	3.94	1.50	12.46	52	1.03
SLT016	545	849	4.77	7.43	3.71	26.09	130	1.56
SLT020	724	1109	7.90	12.09	5.53	38.00	188	2.44
SLT025	1003	1593	21.99	43.01	10.35	68.59	285	3.80
SLT030	1160	1960	30.26	62.93	15.68	93.27	395	5.49
SLT040	2972	4033	105.37	176.05	36.59	264.34	843	9.69
SLT050	4086	5615	179.89	304.35	51.58	428.72	1758	15.19